

OWL F9F-Cougar

6s 70mm EDF
User Guide



Rev. 1.0

Table Of Content

OWLplane 3D Printed Models	3
OWL F9F-Cougar 70mm EDF jet	4
3 Variants of F9F-Cougar 70mm Models	5
Utilizing OrcaSlicer.....	7
Like Playing Lego (PLA, Digital Balsa, Digital Balsa & Foam):	8
Expected Some Stringing but Easy to Clean	9
Cleaning Parts.....	10
Sand The Surfaces To Get Smooth Ones.....	10
Specification	11
Center of Gravity (CoG).....	11
Spar Requirement	12
Locking Belt for Attaching Wings to Fuselage	13
Aileron/Wing Control Surfaces Rods.....	14
Elevator Control Surfaces Rods:	14
Please Use 15mm Pins to Assembly FUSELAGE-4 and 5.....	15
Please Use 15mm Pins to Assembly 70F9FC WING-L-2 and 70F9FC WING-L-3.....	15
Cut Some Areas for LW-PLA Parts Only.....	16
ESC Management Positions	17
70mm EDF Bracket and Installation.....	18
EDF Lid Assembly	19
Canopy Assembly Support Rod and Pins.....	20
How to Launch OWL F9F-Cougar 70mm EDF Model.....	21
Print The Launcher Adapter Below.....	23
Finger Resting for Hand Launching (Optional).....	26
Optional : Fiber Tape Protecting The Model During Belly Landing.....	27
Weight and Time Estimation.....	28
Recommended Setup.....	29
Tools and Materials	30
Hardware Needed	31
Setup for Servo Travel/Throw.....	32

OWLplane 3D Printed Models

Thank you for supporting our RC Flying Models. Our journey began in 2018, fueled by a passion for 3D printing technology. After years of refining our techniques and perfecting our designs, we are proud to share our models with the world. Every aircraft we release is crafted to be fun to fly, easy to assemble, and optimized for the perfect balance of strength and weight.

3D printing is rapidly becoming a cornerstone of the aeromodelling hobby, and we are excited to be part of that evolution! The biggest challenge has always been printing a single-perimeter structure that stays both light and durable, as most filaments are much heavier than traditional materials. Thankfully, LW-PLA provides the perfect solution. We designed the OWL F9F-Cougar 70mm EDF to work with both standard and lightweight filaments, though we highly recommend LW-PLA for the best possible experience in the air.

A significant hurdle in 3D-printed aeromodelling is the complexity of assembly, which rests entirely on the quality of the initial CAD design. A successful designer must balance weight reduction with structural simplicity to ensure the build remains accessible. When engineering a 3D-printed aircraft, we prioritize several critical design factors, including but not limited to:

- Material Density and Other Characteristics (filament types and its characteristics)
- Printer Capability Delivering Printed Object (printer and its technology used)
- Single Parameter Printing Technique (slicer capability)
- Design Factor (CAD model itself)

We recognize these challenges and are committed to constant improvement. This hobby is still in its early stages, and there is immense potential for growth. Because the spirit of aeromodelling is rooted in innovation, our search for better solutions and new technologies will never truly be finished.

HAPPY AND SAFE FLYING

OWL F9F-Cougar 70mm EDF jet

This F9F-Cougar 70mm model is designed for flexibility and ease of use. Whether you're a seasoned maker or a weekend hobbyist, we've simplified the process to get you from "download" to "takeoff" faster.

3 Ways to Print (PLA, LW-PLA "Digital Balsa" and LW-PLA "Digital Balsa and Foam")

We provide three distinct variants based on your preferred filament. Each variant comes with its own set of STL files and slicing profiles.

Mix & Match: You aren't locked into one style; feel free to mix parts from different variants to suit your needs.

Powered by OrcaSlicer (New for 2025 and Onward)

Printing is now much more reliable because our profiles are built in OrcaSlicer, which supports the vast majority of FDM printers on the market.

Project Files Included: We don't just give you the STLs; we provide the full Project files.

The "Easy Mode" Process: If your printer is on our supported list, simply select your machine, choose your filament, and match it to the STL reference code. That's it!

Custom Support: If your printer isn't listed yet, don't sweat it. OrcaSlicer makes it incredibly easy to create a custom profile.

Recommended Setup

Battery: Use a 4S 2200mAh battery.

Build: Print using the LW-PLA "Digital Balsa" approach (no infill). This keeps the model lightweight, which makes landings much easier.

Launching & Maiden Flight





If you aren't experienced with hand-launching EDF jets, we recommend using our Catapult Launcher. It eliminates the risk of "human error" or a bad toss.

Practice First: Use the catapult for your maiden flight to get a feel for how the model handles.

Trim & Relax: Once you have the ailerons and elevator properly trimmed, the plane will be much easier to manage, and you won't have to worry about fighting the controls during launch.

3 Variants of F9F-Cougar 70mm Models

We provide three distinct printing versions for these models. Every version has been flight-tested to ensure it's not only fun to fly but also tough enough to handle high-G maneuvers.

Feature	Standard PLA	Digital Balsa	Digital Balsa & Foam
 Weight	Heaviest	Lightest Best Performance	Balanced
 Flight Difficulty	Hardest High Wing Loading	Easiest / Most Agile	Stable
 Durability	Very Strong	Most Fragile	Strong
 Print Time/Cost	Fastest & Cheapest	Moderate	Moderate 

Standard PLA: Great if you're on a budget or a schedule. It's the heaviest and most challenging to fly, but as you can see in our videos, it's still a blast.

Digital Balsa: This is the high-performance choice. It has the lowest All-Up Weight (AUW), though it requires a gentler touch as it is structurally the most delicate.

Digital Balsa & Foam (LW-PLA): Often the "sweet spot" for most pilots—offering great strength without the heavy weight of standard PLA.

Launch Recommendations

To keep your model in one piece, we recommend the following:

Use a Catapult: We strongly advise against hand-launching the heavy PLA series.

Avoid Human Error: Regardless of the model you choose, using a catapult is the safest way to ensure a successful takeoff every time.

Technical Insight: "Digital Foam" & Ribs

When we say "Digital Foam," we're referring to the use of gyroid infill during the printing process.

Strength Control: You can adjust the infill percentage to your liking—higher percentages mean a stronger (but heavier) plane.

Internal Ribs: We've designed these models with internal ribs to provide maximum support while using the most efficient amount of gyroid infill.

Customization: If you want to modify or remove internal structures to save weight, check out our OrcaSlicer profile page for a step-by-step guide.



BambuLab PiS



BambuLab A1



BambuLab A1 Mini



Crealty KiC



Crealty Hi

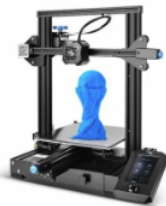

Crealty Ender-3 / Marlin

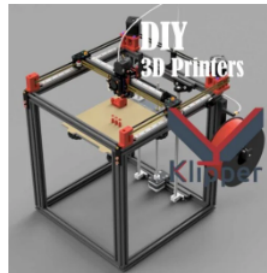

DIY Klipper



DIY Klipper

3D Printed Aircraft Modeling Styles & Material Selection (Direct from Table)

	(1) Standard Model (PLA Series)	(2) Digital Balsa (LW-PLA Series)	(3) Digital Balsa & Foam (LW-PLA Series)
Style			
Filaments	Standard PLA, PLA+, Hyper PLA, HF-PLA, ABS, PETG	LW-PLA (eSUN, 3DLabPrint, ColorFabb, BambuLab), ASA Aero, LW-ASA, LW-PLA-HT	LW-PLA (eSUN, 3DLabPrint, ColorFabb, BambuLab), ASA Aero, LW-ASA, LW-PLA-HT
Charac:	Retraction Enabled No-Infill used.	'Single-Pass/Vase-Mode' No Infill used.	Uses 3% Gyroid Pattern Infill
	HEAVIEST MODEL	LIGHTEST MODEL; LEAST STRONG	STRONGER THAN DIGITAL Balsa

Utilizing OrcaSlicer

In 2025 and onward, when we release a new model, it should be sliced using OrcaSlicer. If you would like to know more and download the provided profiles, please visit the following page : <https://owlplane.com/orca-slicer-for-bambulab-and-others/>

Full-Auto Calibration

Auto Bed-Level

Auto Z-Offset

Goodbye to Tedious Manual Calibration And Tuning

A1 handles various calibrations all by itself. It meticulously calibrates the Z-offset, bed-level, vibration resonance and nozzle pressure for EVERY print job, automatically.

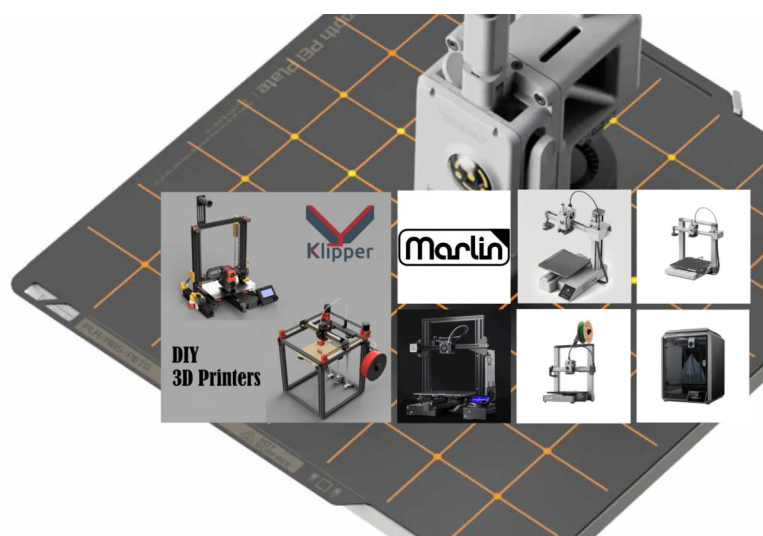

Like Playing Lego (PLA, Digital Balsa, Digital Balsa & Foam):

We always consider designing all of our model easy to assembly. To achieve this, the printed parts are designed such a way when assembly it feels like playing “lego” blocks.

*) Below pictures are sample parts from F16 model.



Expected Some Stringing but Easy to Clean

Since active foaming filaments such as LW-PLA is not affected by retraction, some stringings are expected. The good news is that they are easy to clean compared to printing with standard PLA/PLA+.

Since active foaming filaments such as Suggested using knife to clean initially.

Once completed using knife, continue using sandpaper for sanding some strings that still attached to skin.

Sandpaper could also used to make smoother skin.

For the plug-in blocks, also use sandpaper to eliminate excessive materials

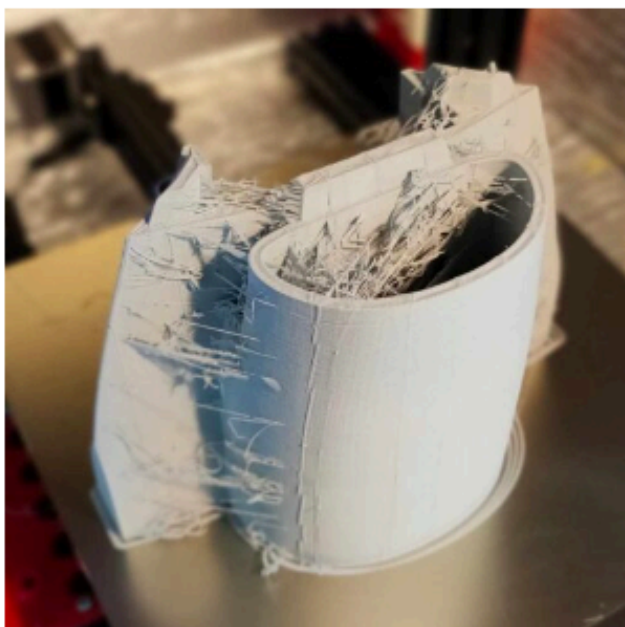

Before cleaning

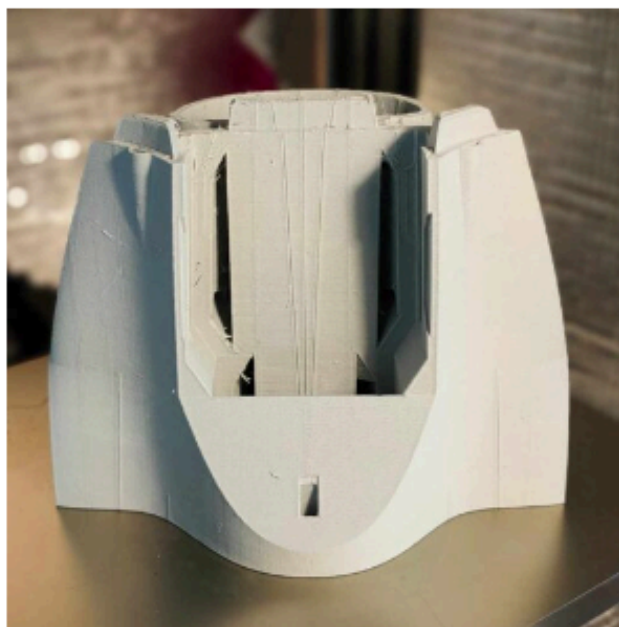

After cleaning

Cleaning Parts

Sanding parts would make assembling much easier and clean. Excessive materials can be found on the top surfaces. For example, the circle in the picture need to sand so that there is no need to push the part later to fit into the next part.



Sand The Surfaces To Get Smooth Ones

Comparing surfaces before and after sending it. LW-PLA material let you smoothing surfaces where it would not be applicable with standard PLA or PLA+.



Illustration before sanding it.

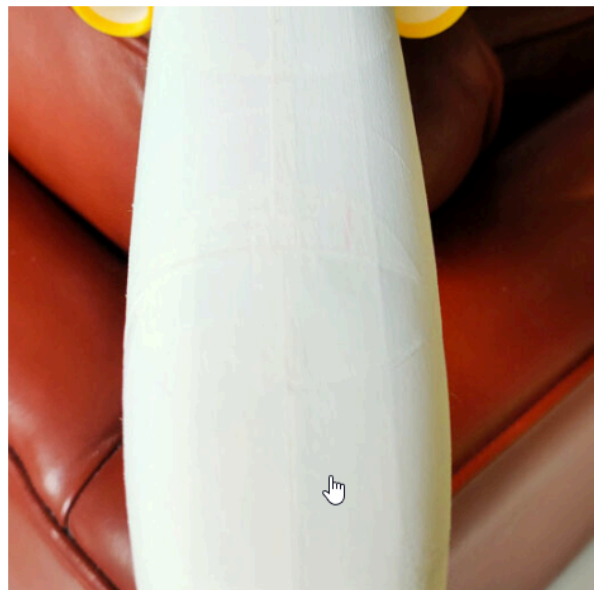

Illustration after sending it.

Specification

Wing Loading : 63.1-82.2 gr/dm².

AUW/Flying Weight : 1727gr-2250gr (with 2800mAh 6s)

Wing Area : 27.36 dm².

Wing Cube Loading (WCL) : 12.1-15.7.

Flight Performance Category : Racer.

Radio Channels : Throttle, Aileron and Elevator.

Length : 1095 mm.

Wing Span : 881 mm.

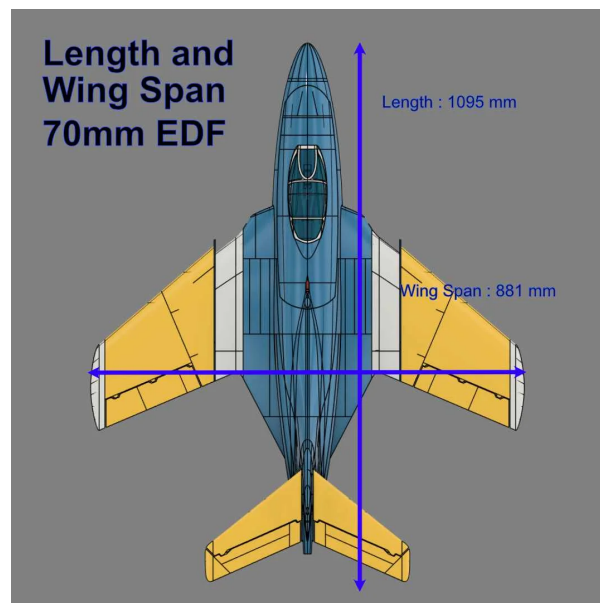

[Click here if you would like to know about WCL \(comparing how easy to fly the plane best described by utilizing WCL instead of Wing Loading. The plane with the same Wing Loading is easier to fly with higher Wing Area than smaller one\). It can be best described by WCL value.](#)

Center of Gravity (CoG)

Use the markers on the wings to find the CoG. The CoG is located around the markers.

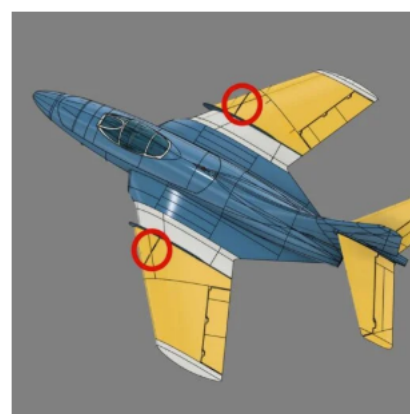
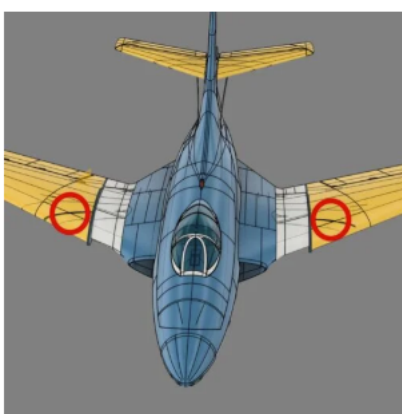

Spar Requirement

- 1 x 8mm OD with 532mm long fiber carbon tube as front fuselage and wing spar.
- 2 x 6mm OD with 330mm long fiber carbon tube as wing spars.
- 2 x 5mm OD with 48mm and 129mm respectively long fiber carbon tube as horizontal spars.
- 2 x 5mm OD with 206mm long fiber carbon tube as horizontal spar.

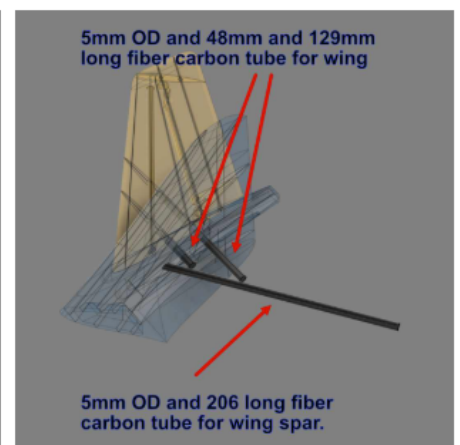
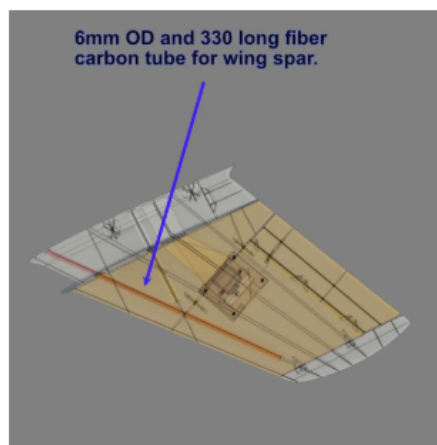
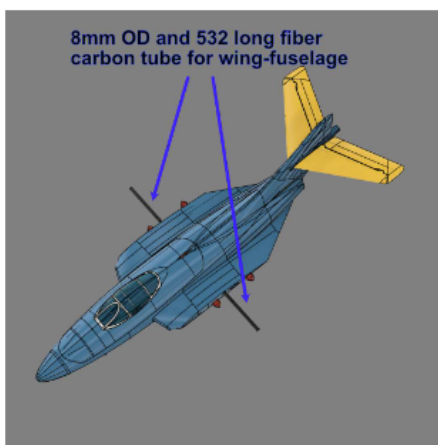

Locking Belt for Attaching Wings to Fuselage

| 4 x “LOCKING-BELT # GR3”

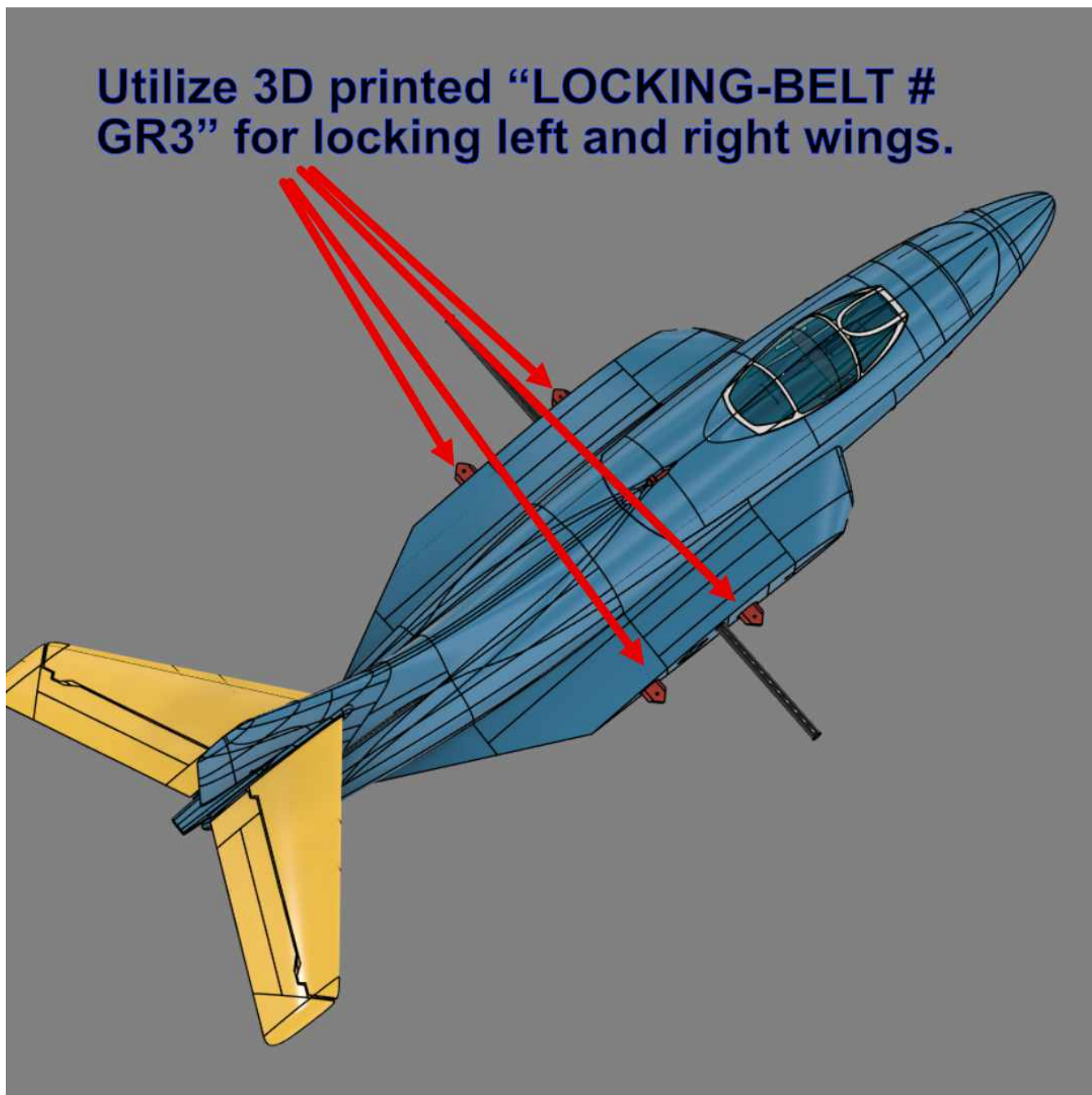

Aileron/Wing Control Surfaces Rods

- Use about 1.5-2mm rod to assembly ailerons.
- Use about 2-2.5mm rod as guide or support for assembling ailerons.

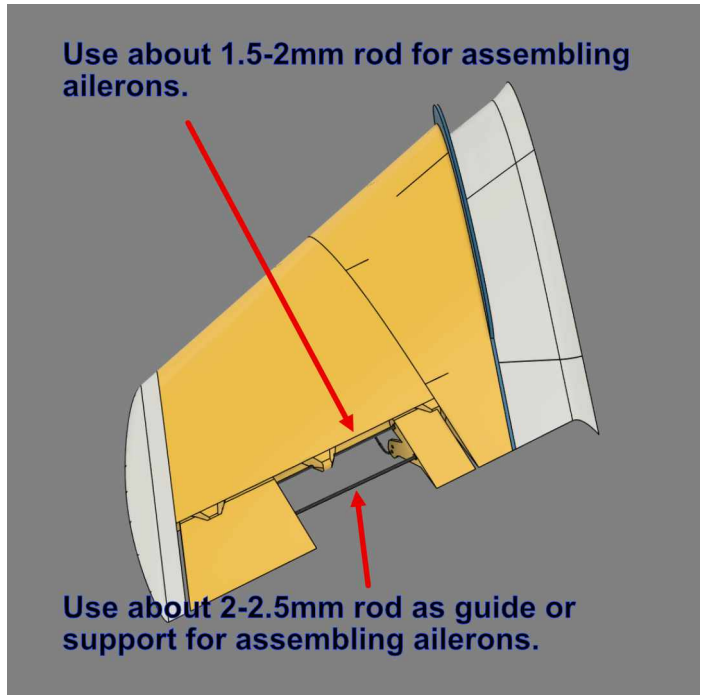

Elevator Control Surfaces Rods:

- Use about 1.5-2mm rod to assembly ailerons.
- Use about 2-2.5mm rod as guide or support for assembling ailerons.

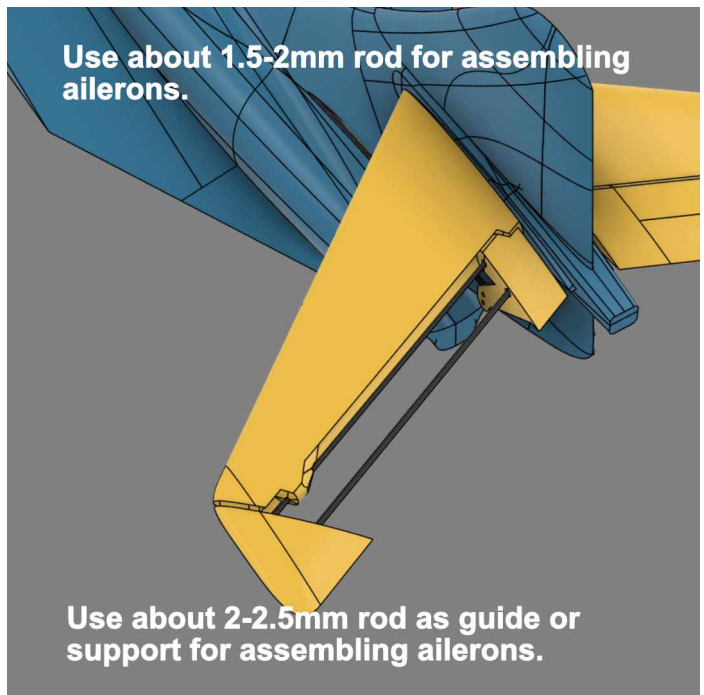

Please Use 15mm Pins to Assembly FUSELAGE-4 and 5.

To glue FUSELAGE-4 and FUSELAGE-5, need to use 3 x 15mm pins as shown below. The pin STL files can be found under : "1. STLs F9F-Cougar 70mm\SUPPORT v1.0\PINS - please use 15mm PIN"

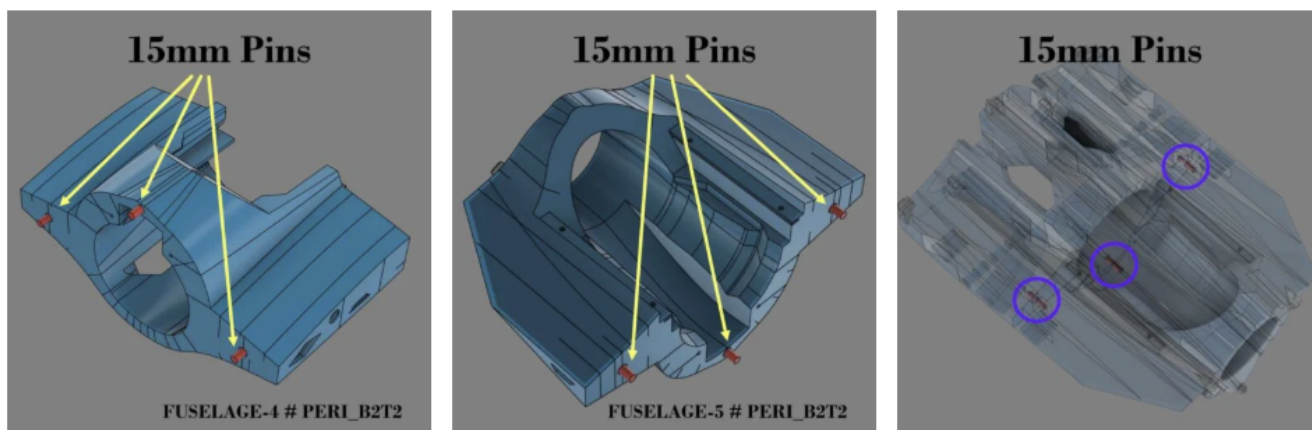

Please Use 15mm Pins to Assembly 70F9FC WING-L-2 and 70F9FC WING-L-3

To glue Please Use 15mm Pins to Assembly 70F9FC WING-L-2 and 70F9FC WING-L-3, may use 2 x 15mm pins as shown below. The pin STL files can be found under : "1. STLs F9F-Cougar 70mm\SUPPORT v1.0\PINS - please use 15mm PIN".

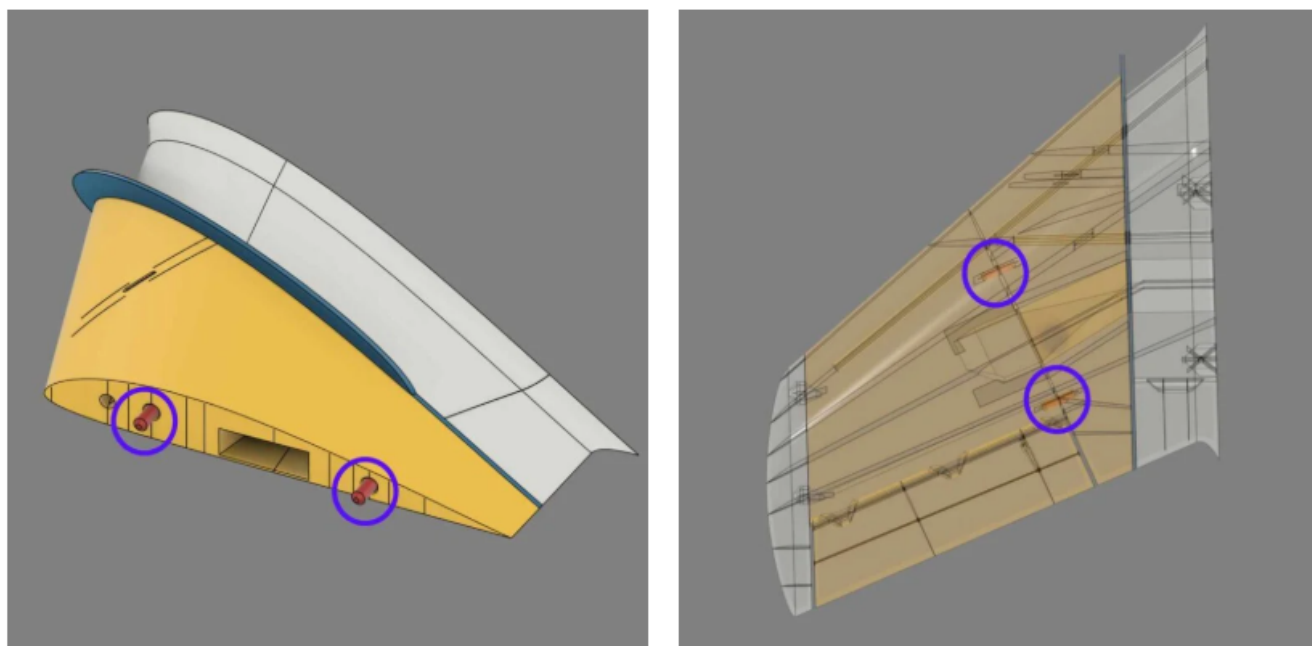

Cut Some Areas for LW-PLA Parts Only

Only for FUSELAGE areas printed with LW-PLA (the parts designed that way to avoid travelling).

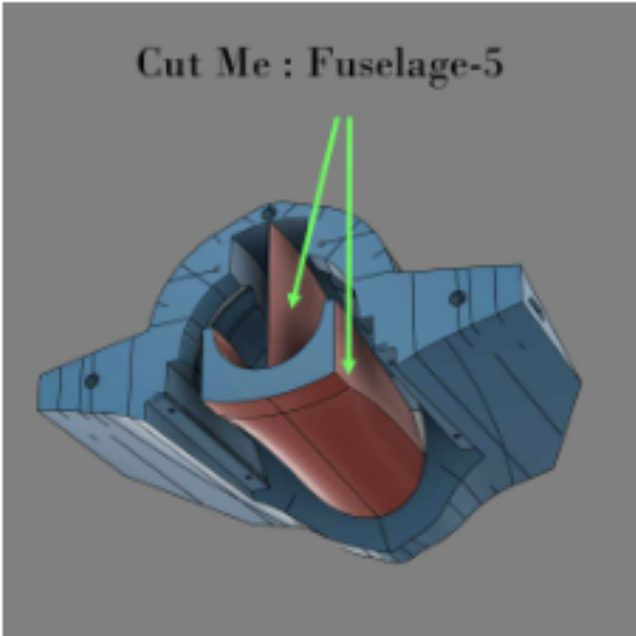
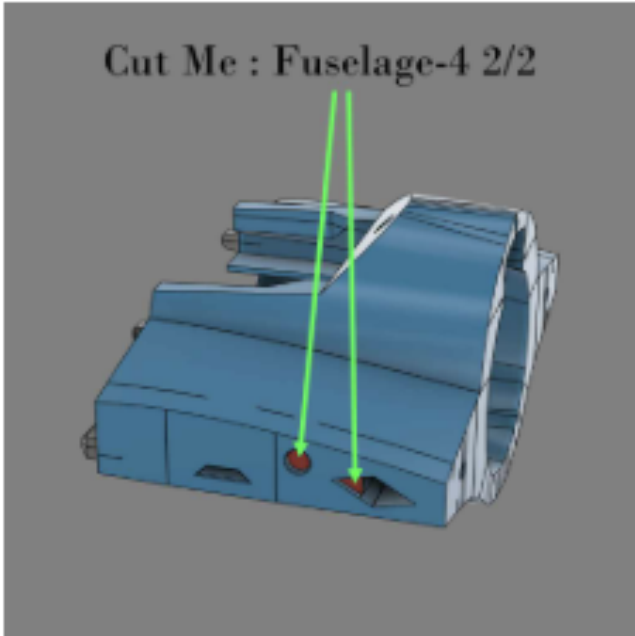
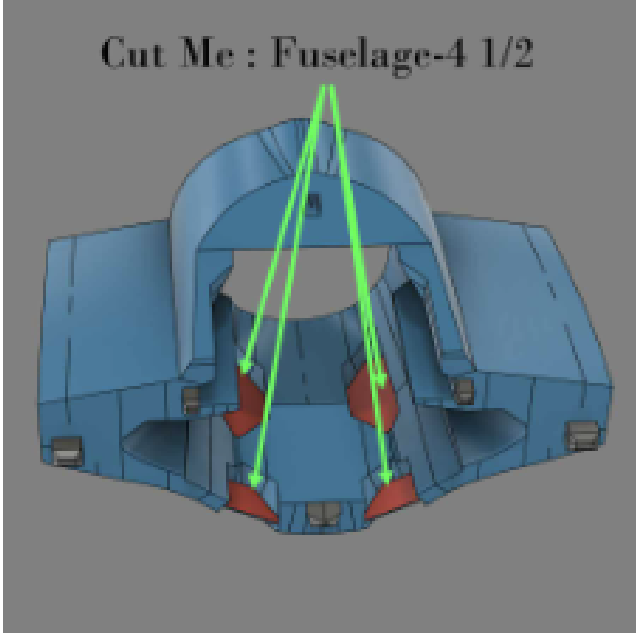
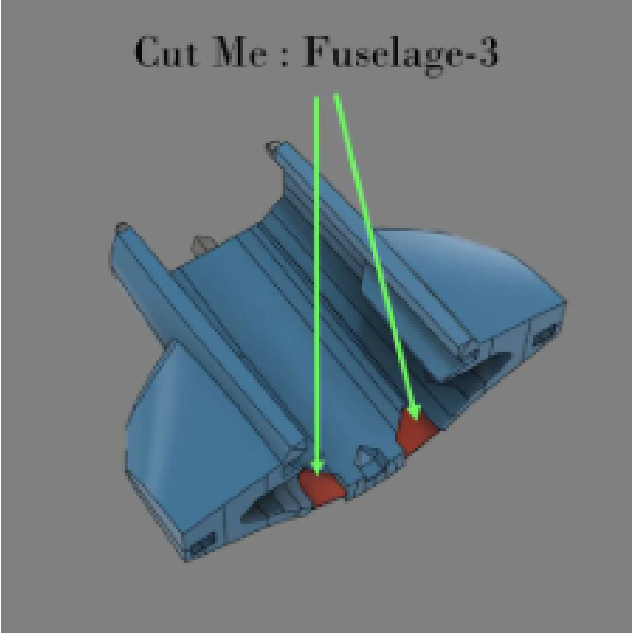

ESC Management Positions

Feel free to locate the electronics for getting the correct CoG.

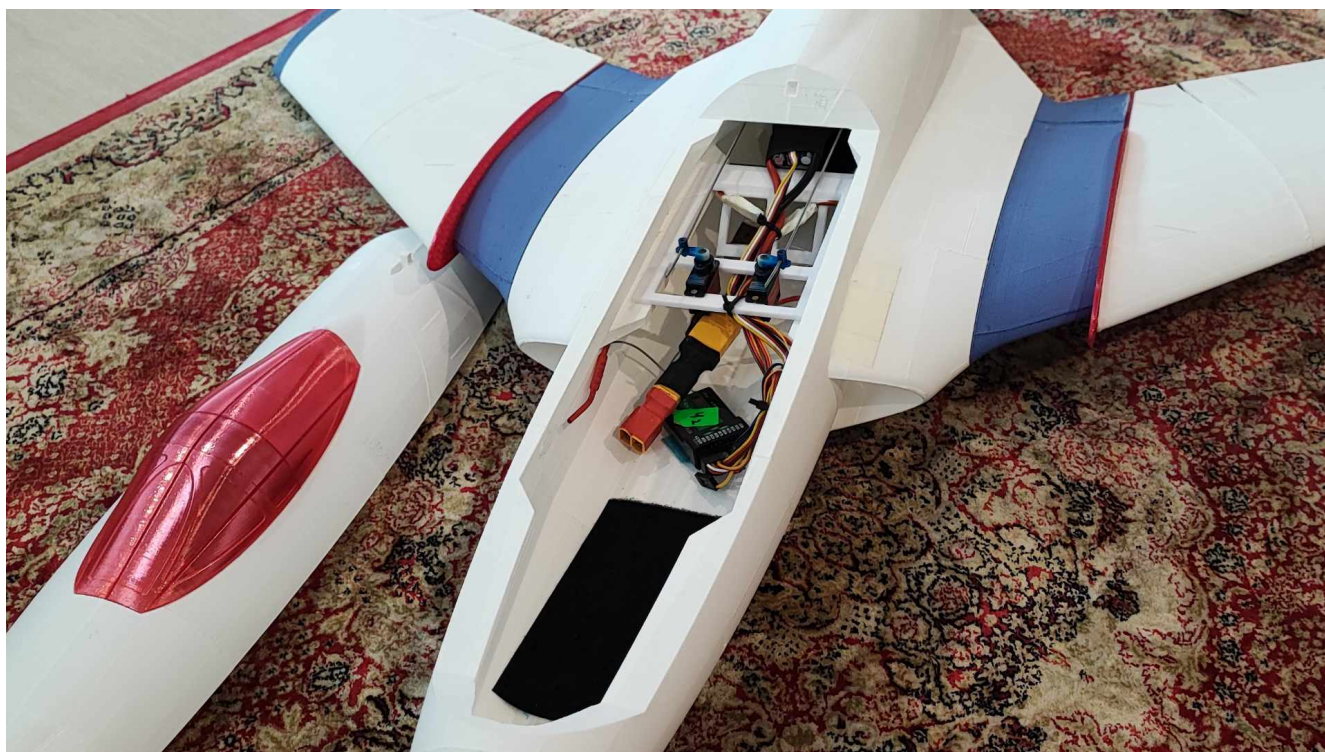
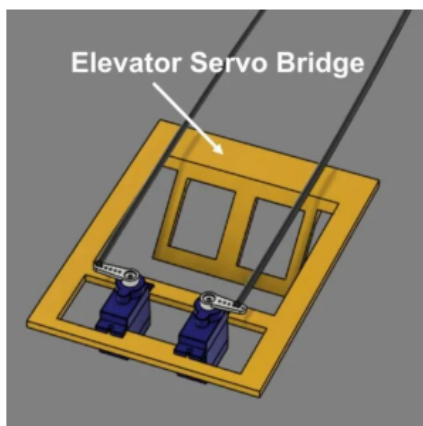

70mm EDF Bracket and Installation

Feel free to locate the electronics for getting the correct CoG.

Right side pictures show how 70mm EDF installed into the fuselage.

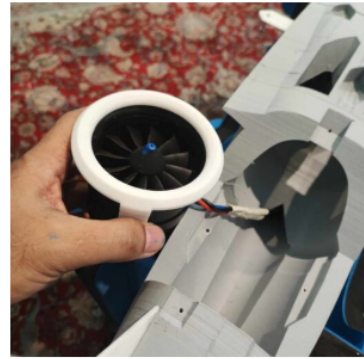
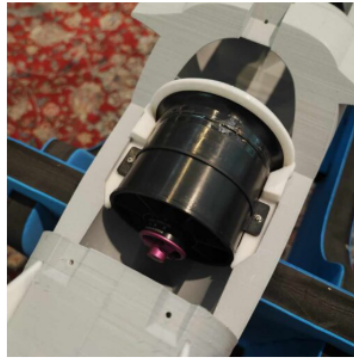

*) The pictures are from OWL ViperJet 70mm.

*) For illustration only; the picture taken from 64mm EDF when intake lip removed only.

Two sets of EDF brackets can be used. The one with intake lip removed or the one with fixed/taped intake lip.

You can find the bracket STL files under "1. STLs F9F-Cougar 70mm\SUPPORT v1.0\F9F-Cougar EDF BRACKETS 70mm EDF".

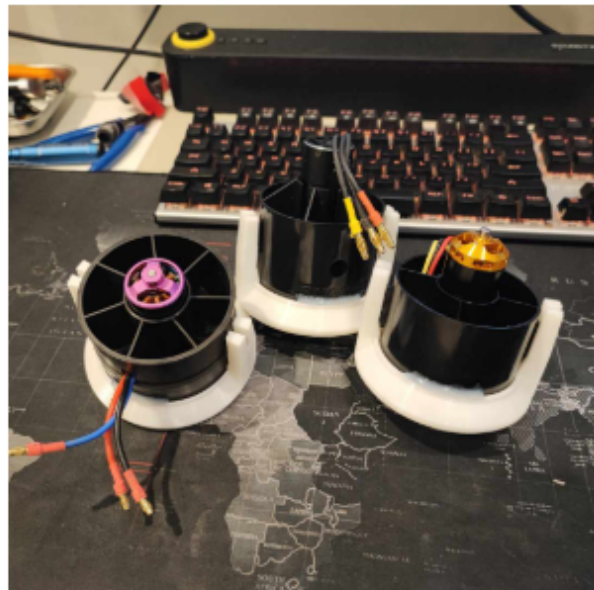

EDF Lid Assembly

Use pins to assembly/glue.

Use The PINs to Assembly

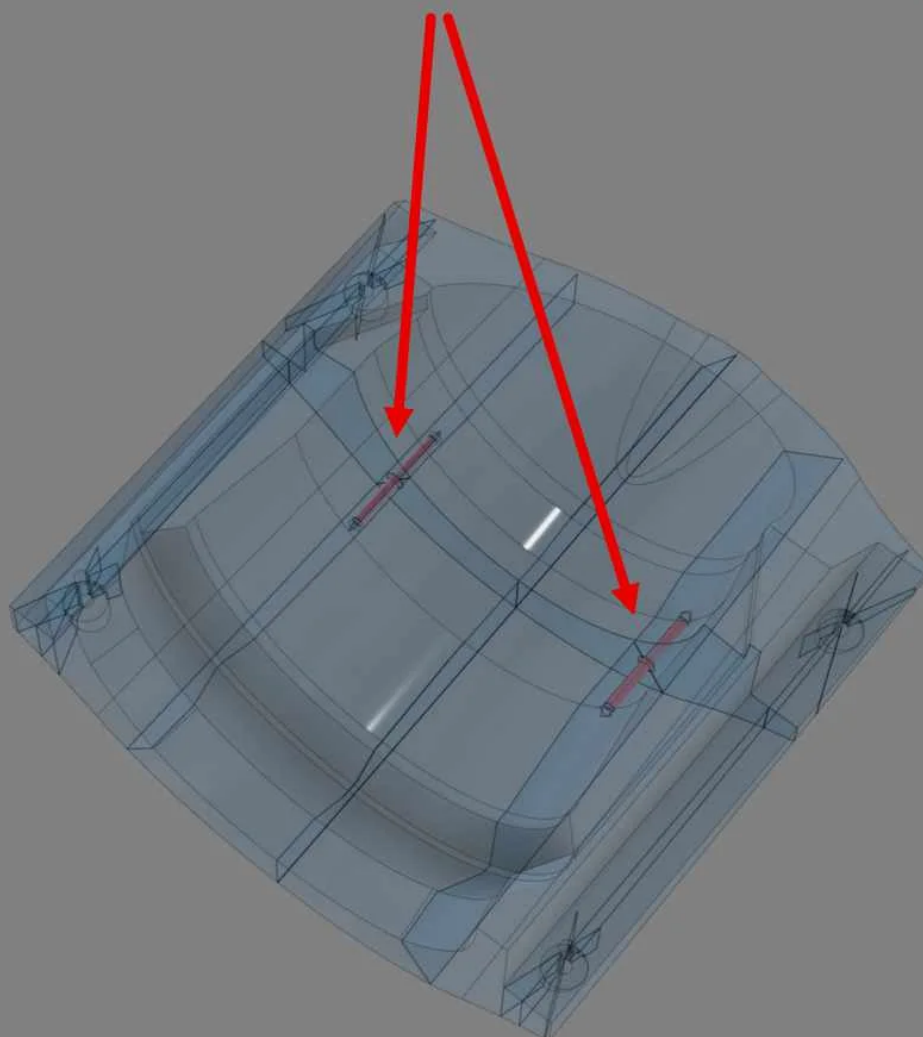

Canopy Assembly Support Rod and Pins

See below figures to assembly the Canopy by using 2-2.5mm support rod.

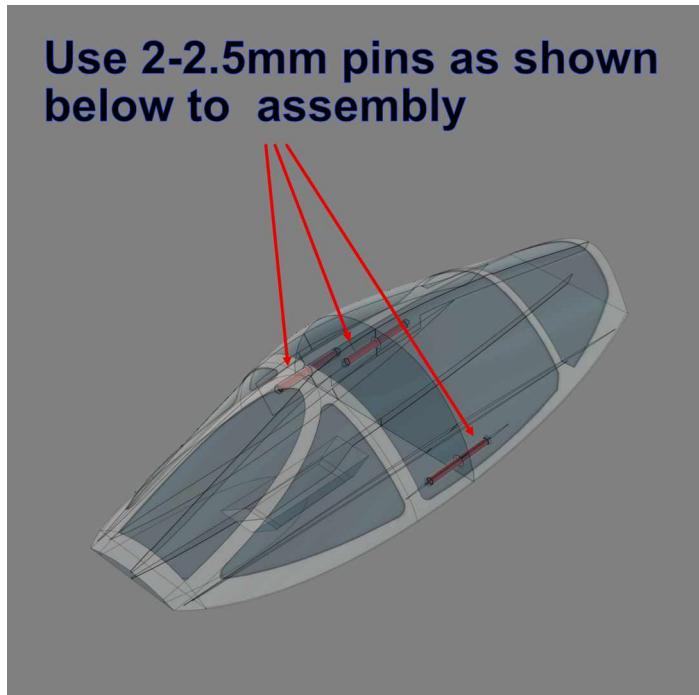
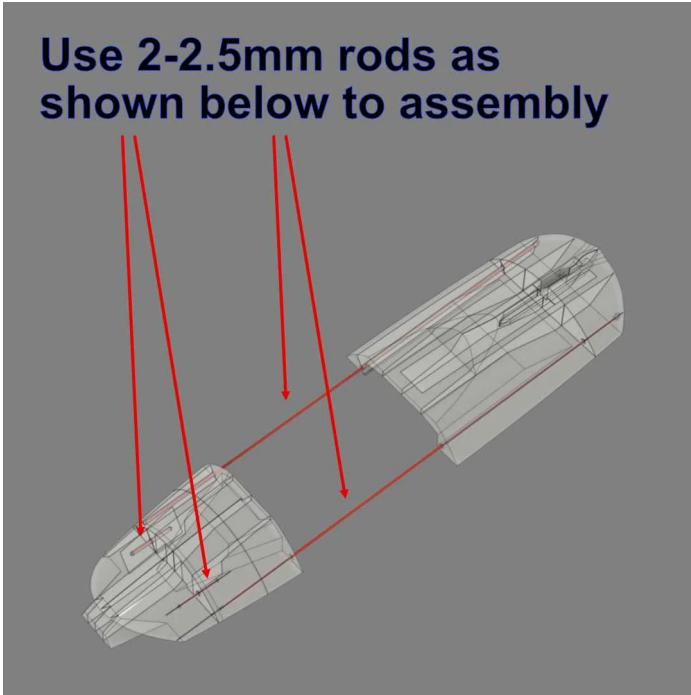

How to Launch OWL F9F-Cougar 70mm EDF Model

Two methods are suggested to launch the model. The first one is to use OWLplane Catapult Launcher. Please visit OWLplane Catapult Launcher product page under “PRODUCTS DETAILS” tab after clicking “OWLplane Catapult Launcher” (you can use your own Catapult Launcher, you may need only to use the adapter). The second one is by hand launching.

It is recommended to launch the model by utilizing OWLplane Catapult Launcher or your own launcher since it is human error free. If you would like to hand launch the model, suggest to print the digital balsa model instead (LW-PLA with no-infill setting).

#1 - By Utilizing OWLplane Catapult Launcher (<https://owlplane.com/owlplane-catapult-launcher-10/>)

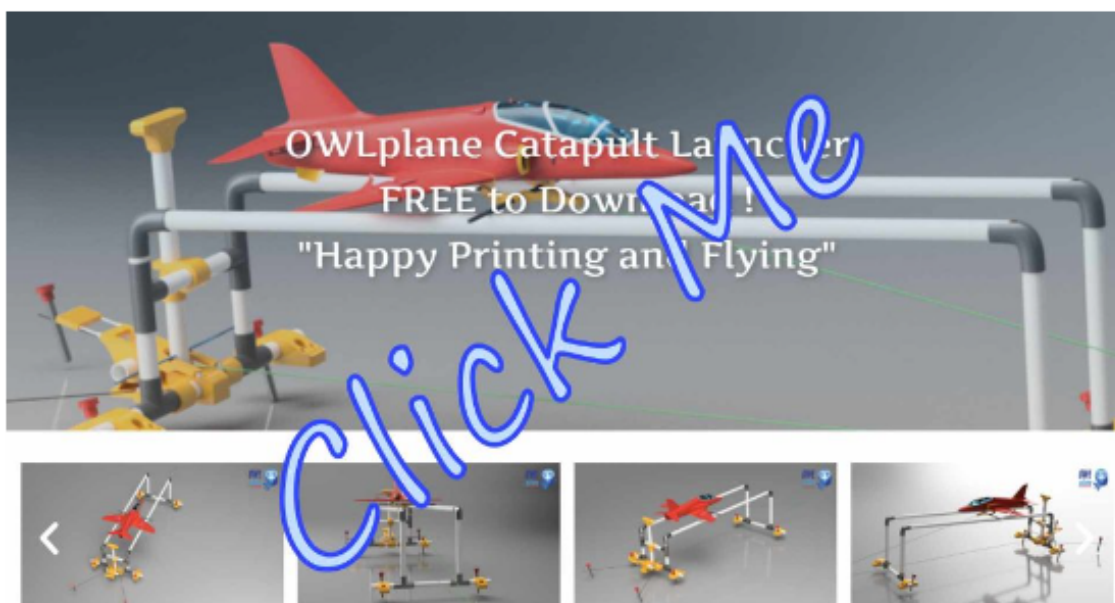

#2 – By Throwing (Print The Model with LW-PLA No-Infill).

Please print the model using LW-PLA with no-infill or we call it “Digital Balsa” type of print. Make sure you use a powerful EDF motor that can have static thrust stronger than the model AUW itself (having more than 1 thrust and AUW ratio).

Follow the following tips to launch :

- Lean your body backward.
- Put your fingers on designated locations (shown in the following section below).
- Start throwing by also moving your body forward.



Note : Above pictures are illustration only, using 50mm BAE Hawk T1 – 50mm EDF instead.

Print The Launcher Adapter Below

To get some degree of wing incidence (if the catapult launcher can not give some degree of wing incidence after laying the model on), please print the launcher adapter as shown below.

If you would like to use your own, you may need to skip the adapter but just need to print the hook.

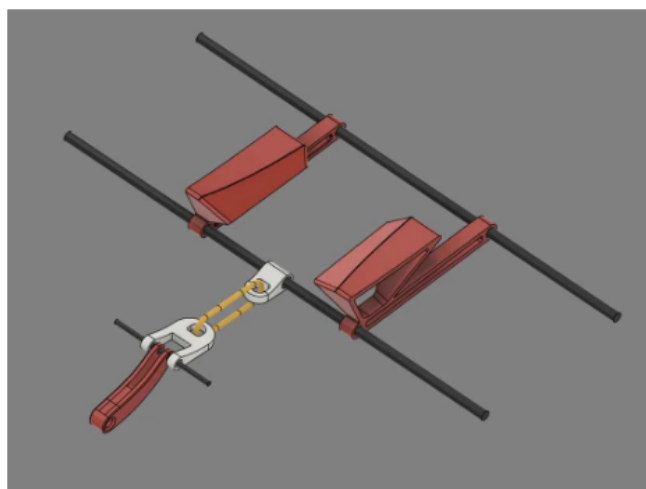
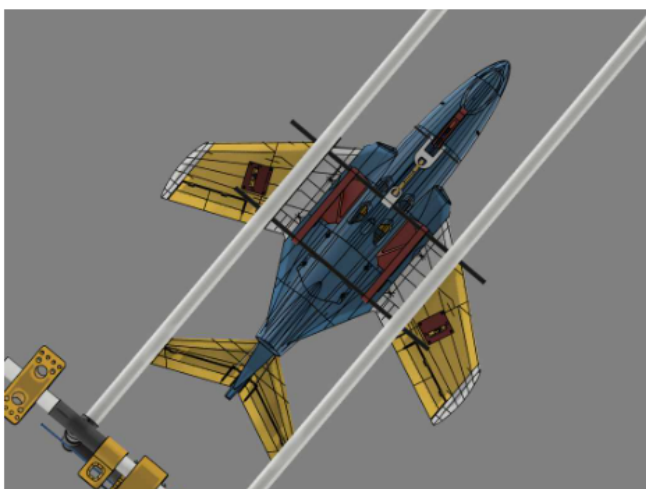
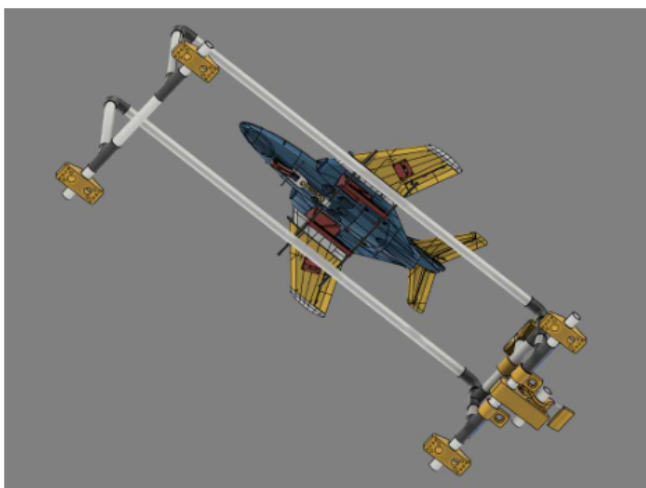

If you plan to launch the model with our own catapult launcher, please print the part shown on the right side. All parts are located under “1. STLs F9F-Cougar 70mm\SUPPORT v1.0\CATAPULT LAUNCHER”.

- 2 x 8mm or 10mm OD with 500mm length tubes (for the arms).
- 1 x 5 or 6mm OD with 10mm length (for the hook).

More details regarding assembling OWLplane catapult set can be found from OWLplane Catapult Launcher product page.



BACK-CONNECTOR # GR3



TOOL-FOR-ROPE # GR3



FRONT-CONNECTOR # GR3



MEASUREMENT-TOOL 64/70mm # GR3

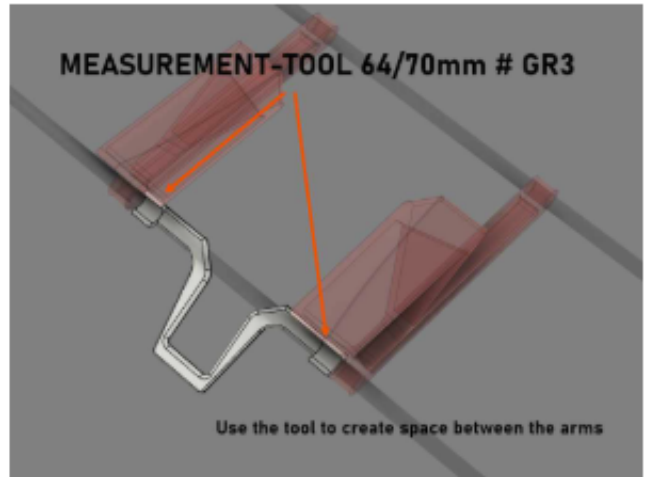
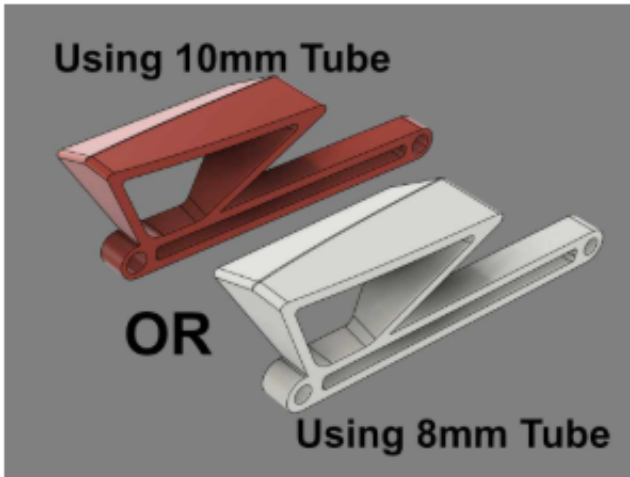
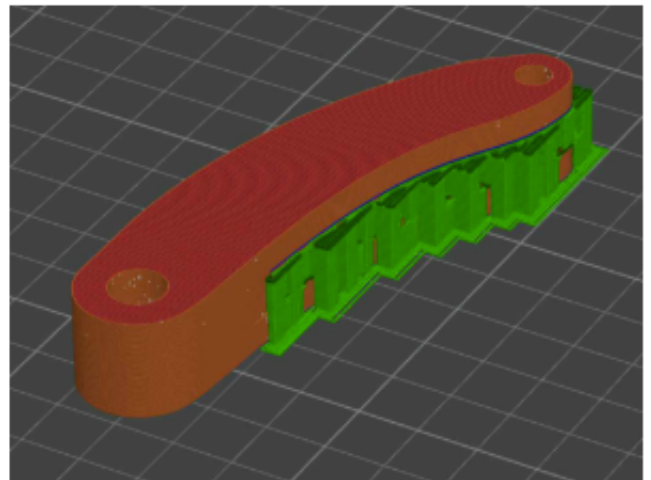

Use tape to create tabs as shown in the picture. The left and right arms should be located approximately where CoG rest on them also as shown by the right side picture (use rope tool to help).

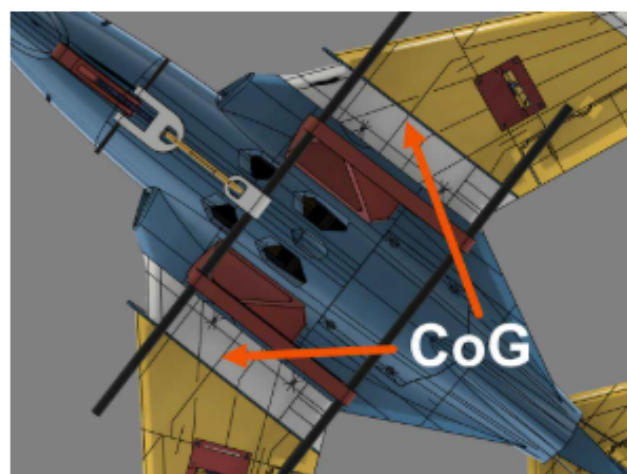
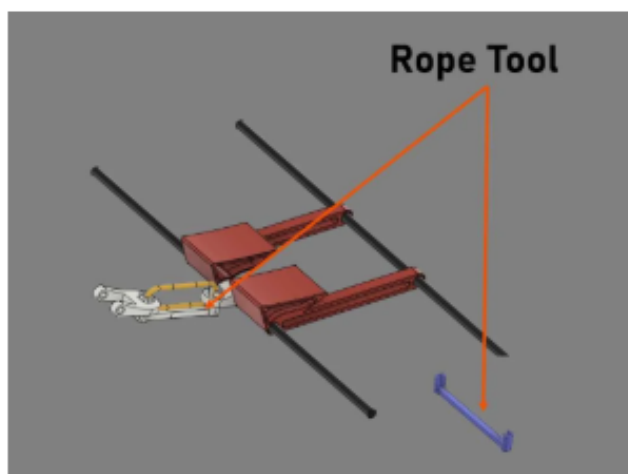
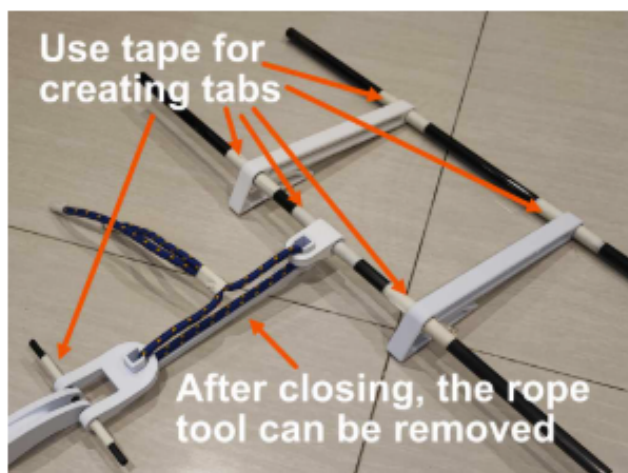

Finger Resting for Hand Launching (Optional)

If you choose to launch by throwing, please put your fingers as shown in the following pictures.

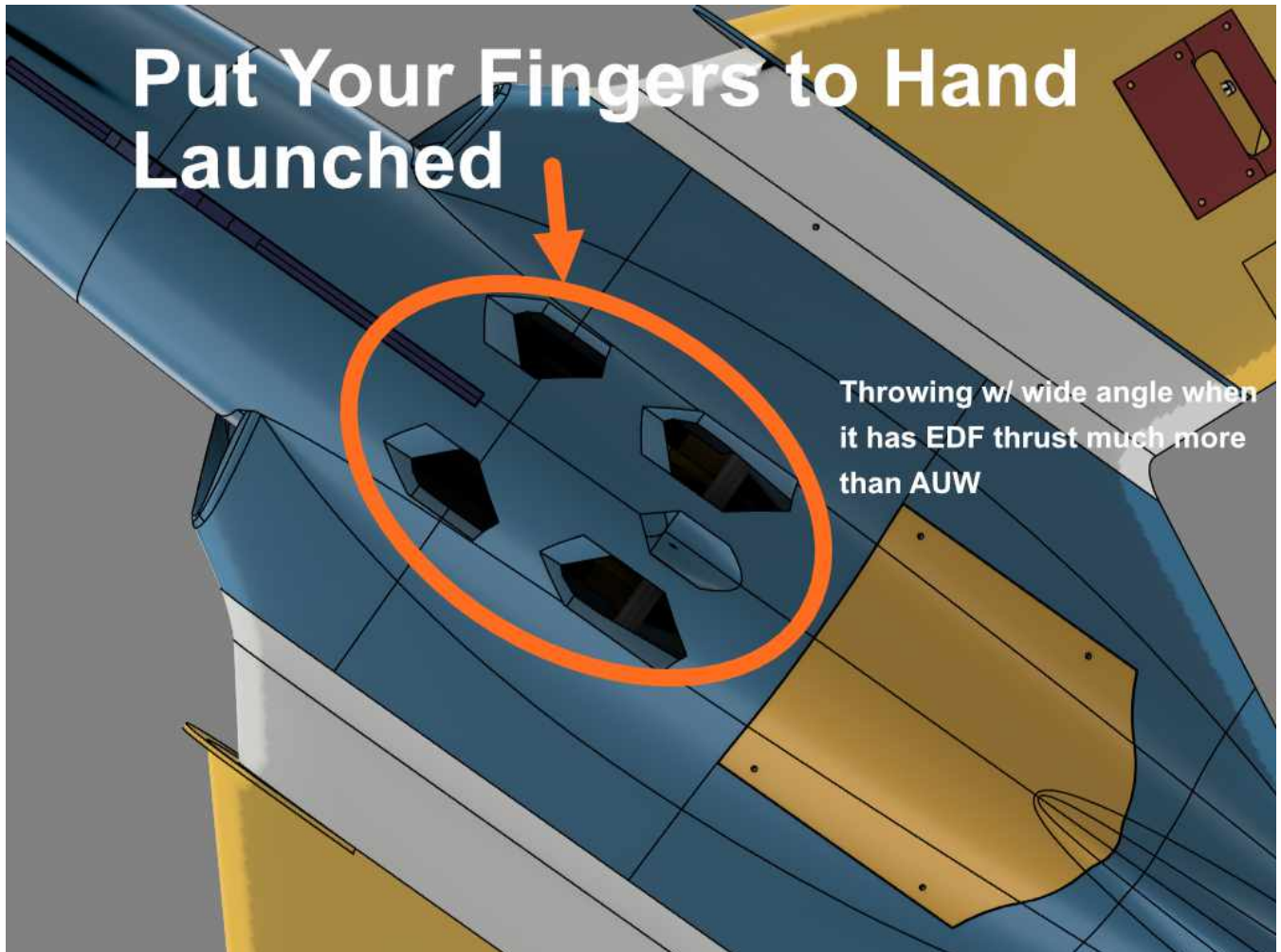

Optional : Fiber Tape Protecting The Model During Belly Landing

By using fiber tape attached to the belly skin, it will protect a model during landing from rough surfaces. Not only protecting, you may no need to clean the belly after sometime by replacing it to get back clean.

We have tested it and really happy with the result. The model is still in a good condition after landing it on rough surfaces.

*) Using F16 belly part as illustration only.

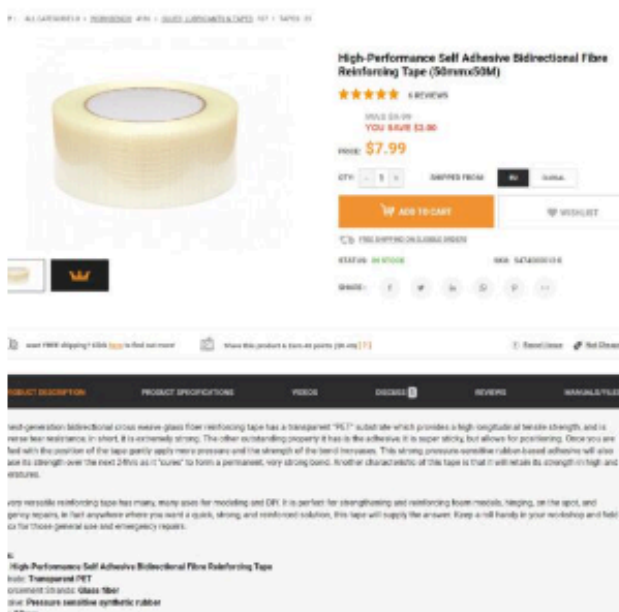

Taken from hobbyking.com website.

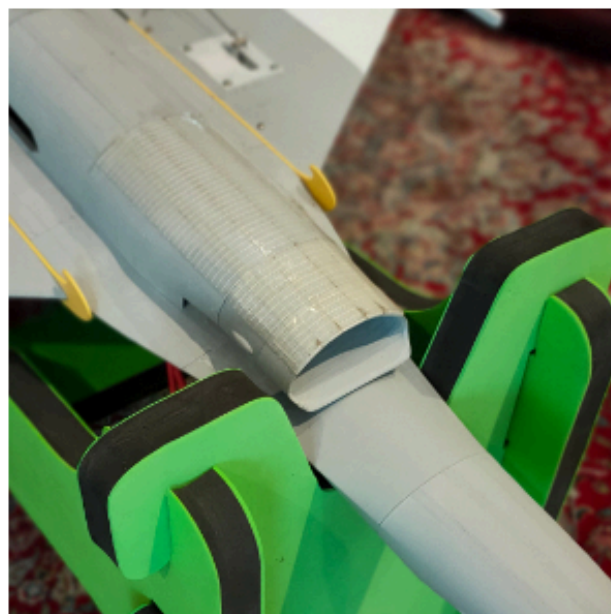

Fiber tape can be replace later when too dirty.

Weight and Time Estimation







Following tables show the weight of printed parts, number of required filament rolls and time required to print. The numbers are taken from S3D slicer calculation. From experience, actual numbers show about -5% less than depicted in the table. But the number may vary from printer to printer due to:

- Stepper Jerk value.
- Stepper Acceleration value.
- Steps per unit (either calibrated or uncalibrated)
- Extruder quality/condition.
- Nozzle quality/condition.
- Filament quality/condition.
- Etc.

No.	Part Names	Weight in grams and Time in Hour and Minute	
		Weight in Grams	Time To Print in Hours
1	FUSELAGE	362.12	50.57
2	WINGS	208.92	32.17
3	STABILIZER	21.79	4.22
4	GLASS CANOPY	54.58	8.60
		647.41	95.55

Summary	
1 ESC + Extension	140.00 grams
2 BATT	500.00 grams
3 EDF + Cover	300.00 grams
4 SERVOS	50.00 grams
5 RECEIVER	15.00 grams
6 SPARS, SCREWS, ETC.	75.00 grams
TOTAL ELECTRONICS	1080.00 grams
Grand Total w/o Painted	1727.41 grams
Grand Total w Painted	1848.33 grams

Recommended Setup

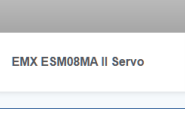
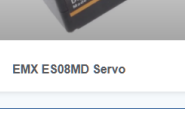
EDF 70mm 6s 17gr Servos for Elevon	EDF 70mm 6s 12gr Servos for Aileron and Elevator
 <p>— Platinum Series Pro V2 Inrunner Motor 6S 12blade Thrust: 2700g Weight: 255g Motor: 3060 KV1900 CNC AL Cap 2020 New FMS 70mm Ducted Fan Jet EDF Unit 6S Pro 12 blade With 3060 KV1900 Inrunner Motor</p>	 <p>POWERFUN EDF 70mm-12 Blades</p> <p>PowerFun 70mm 12 Blades 2300Kv EDF For 6S</p>
 <p>QX-MOTOR KV: 1800 QX-Motor 70mm 12 Blades 1800kv EDF For 6S</p>	 <p>JX PDI-1109MG Servo</p>  <p>Freewing 9gr Digital Servo</p>  <p>FMS 13gr MGDP Servo</p>  <p>EMX ESM08MA II Servo</p>  <p>EMX ES08MD Servo</p>

Motor Options : Powered with 70mm EDF 6s (see above but not limited to).

Servo Options : 4 x 12gr servos for aileron and elevator (left and right).

ESC Options : ESC 80A, please consult to your EDF manual if safe enough to use that rated Ampere value.

Battery Size : LiPo 6s 2200mAh - 3300mAh rated 70C with weight around 400-600gr.

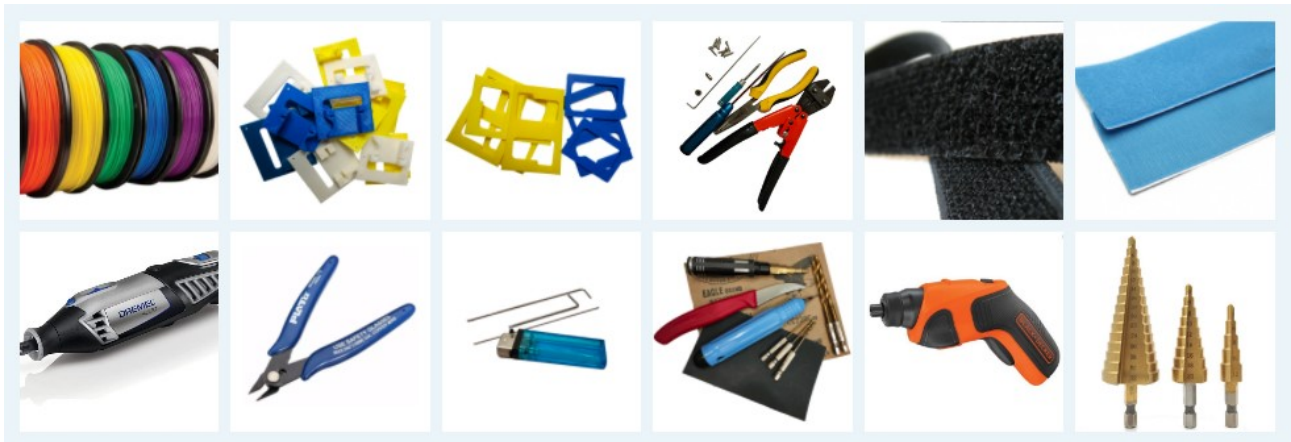

Tools and Materials

Printer, in general 210mm x 210mm x 210mm (W x L x H) for all OWLplane Models.

Filament: LW-PLA from ColorFabb, ePLA-LW from eSUN and PolyLight 1.0 from 3DLabPrint.

CA glue with accelerator. Use thick glue to join surface to surface. Use thin CA glue for coating the joint surface areas.

Velcro sticker/polyester hook and loop peel-n-stick self-adhesive for locking the battery.

Fine sandpaper.

Sharp knife.

Screwdriver and/or allen wrench for chosen screws/bolts.

Pliers, needle-nose pliers, nippers.

Steel bolt cutter.

Dremel/rotary tool for cutting carbon fiber tubes and rod with more than 2.5mm.

Electric drill, its drill-bit size from 1.5mm - 5mm and step cone drill.

Propeller shaft reamer or hole puncher reamer.

Hardware Needed

For Fuselage and Canopy:

Self tapping screw M3x25mm or M2.5x25mm with their washers (optional) for mounting left and right wings including fuselage lid - 6x (4x wings and 2x EDF lid).

Ballpoint pen springs for Canopy - 1x.

For Aileron and Elevator:

1.5 - 2.0mm rod for aileron and elevator hinges (ER308L - TIG Stainless Steel Rod but preferred TIG Aluminum Rod instead).

2.0 - 2.5mm rod for aileron and elevator pushrod (ER308L - TIG Stainless Steel Rod).

2.0 - 2.5mm rod for aileron, elevator and canopy support (ER308L - TIG Stainless Steel Rod).

Landing gear wheel stop set collar D2.1mm or D2.6mm for aileron and elevator 4x.

Linkage stopper D2.1mm or D2.6mm for aileron and elevator - 4x.

Self tapping screw M2.5/M2.0x15mm or M2x15mm for mounting left and right aileron servos - 8x.

Self tapping screw M2.5/M2.0x15mm or M2x15mm for mounting left and right elevator servos - 4x.

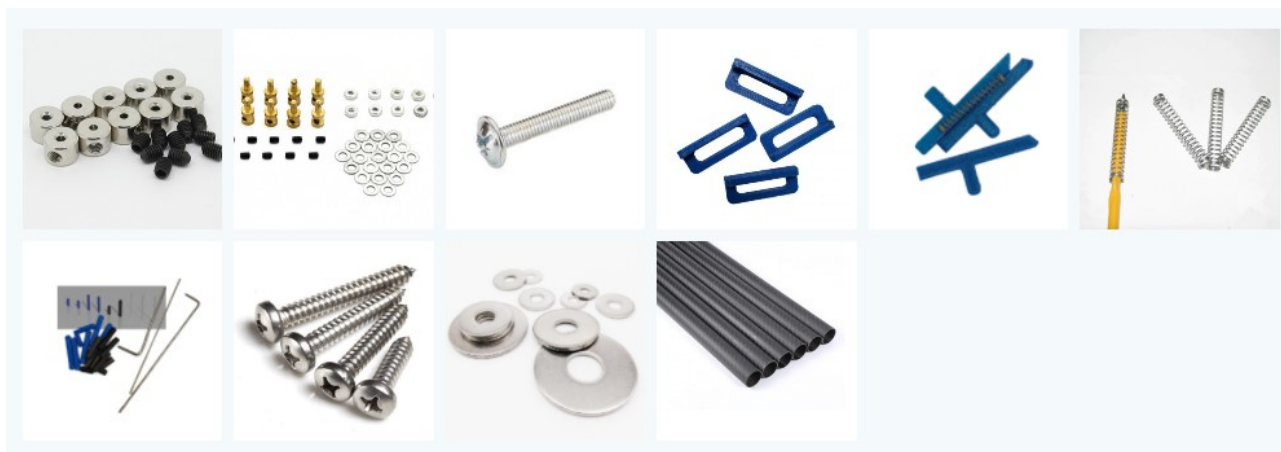

Setup for Servo Travel/Throw

Suggested setup for medium travel/throw are depicted below and you may adjust the setup according to your need.

- Aileron = 10.0mm.
- Elevator = 16.0mm.

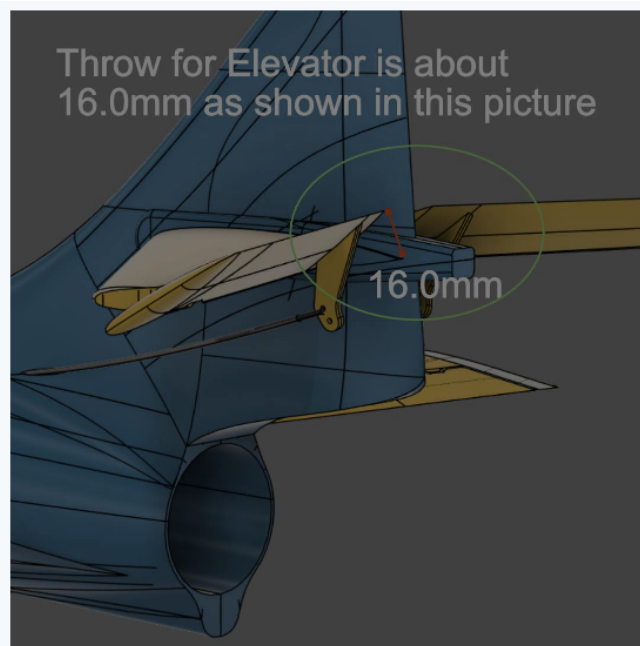
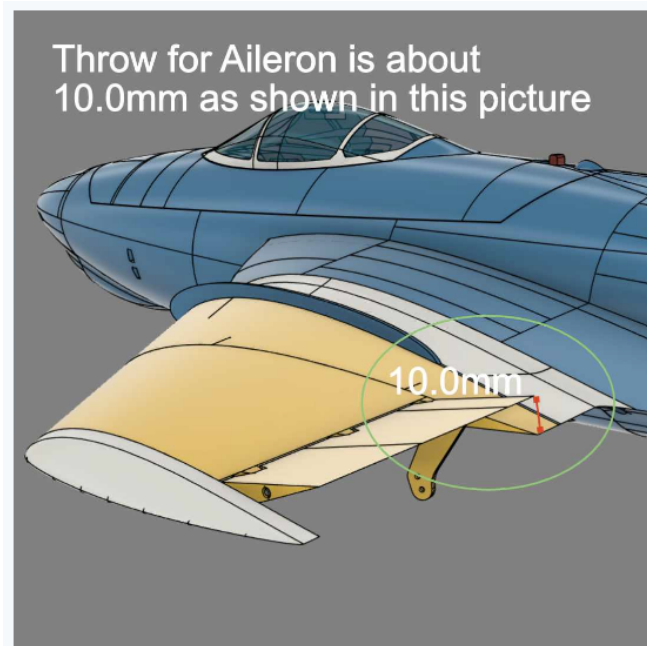

Always keep the RC Model Airplane in view and under control.
Always keep the transmitter switched on when the RC Model Airplane is switched on.
Always remove the battery before disassembling the RC Model Airplane.
Keep moving parts clean and dry at all times.
Always allow the parts to cool before touching them.
Always remove the battery after use.
Make sure that the Failsafe is properly set before the flight.
Never operate the model with damaged wiring.
Never touch moving parts.

Contact Us:

FB - <https://www.facebook.com/OWLplanePilot>

Instagram - <https://www.instagram.com/owlplanepilot>

Youtube - <https://www.youtube.com/channel/UCdmaSQaqYB1TcjpgIqmr1FA>

E-mail - dolly.siregar@OWLplane.com

AGE RECOMMENDATION 14+

**NOT FOR CHILDREN UNDER 14 YEARS.
THIS IS NOT A TOY!**

By using our download files, an RC Model Airplane can be manufactured using a 3D Printer from our Model Design.
By purchasing our Model Design, you are responsible for safe operation that does not endanger you or others, or that does not damage property of others.
OWLplane assumes no responsibility for any damage to persons and property caused by related the usage of our Model Design.
Filaments, printing supplies, hardware or consumables that can not be used after faulty 3D printing will not be replaced by OWLplane in any way.
When operating, always keep a safe distance from your model in all directions to avoid collisions and injuries.
The RC Model Airplane is controlled by a radio signal. Radio signals can be disturbed from outside without being able to influence it. Interference can lead to a temporary loss of control.
Always operate your model on open terrains, far from cars, traffic and people to minimize risk.
Always follow the instructions and warnings for this product and any optional accessories (servos, receivers, motors, propellers, chargers, rechargeable batteries, etc.) carefully.
Keep all chemicals, small parts and electrical components out of the children reach.
Avoid water contact with all components that are not specially designed and protected. Moisture can damage the electronics.
Never take an item of the model or accessory in your mouth as this can lead to severe injuries or even death.
Never operate your model with low batteries in the transmitter or RC Model Airplane.

Please note that the models have potential risks although we create our models to our best of knowledge and belief. We accept no liability for consequential damage and injuries caused by improper use. Be careful when handling motors, batteries, EDF, propellers, etc. and make sure you play in under safe environment.